

DESCRIPTION

- Brass construction with chrome plated finish
- 1/2" IPS connections
- 8" centers
- Less spout
- Vandal resistant torx head screws

OPERATION

- Lever style handles with hot and cold color indicators

CARTRIDGE

- Brass shell, ceramic disc cartridge
- 1/4 turn operation

STANDARDS

- Third party certified to meet ASME A112.18.1/CSA B125.1 and all applicable specifications referenced therein
- Contains no more than 0.25% weighted average lead content
- Certified to NSF 61/9
- Complies with California Proposition 65 and with the Federal Safe Drinking Water Act

- **ADA**  for lever handles

WARRANTY

- Warranted for five years against material or manufacturing defects

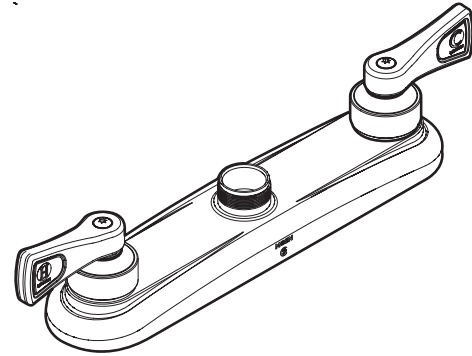

Two-Handle Kitchen Faucet

MODELS: 8280

NOTE:
Designed to be installed through
2 or 3 holes - 1" min. dia. and on 8" on center

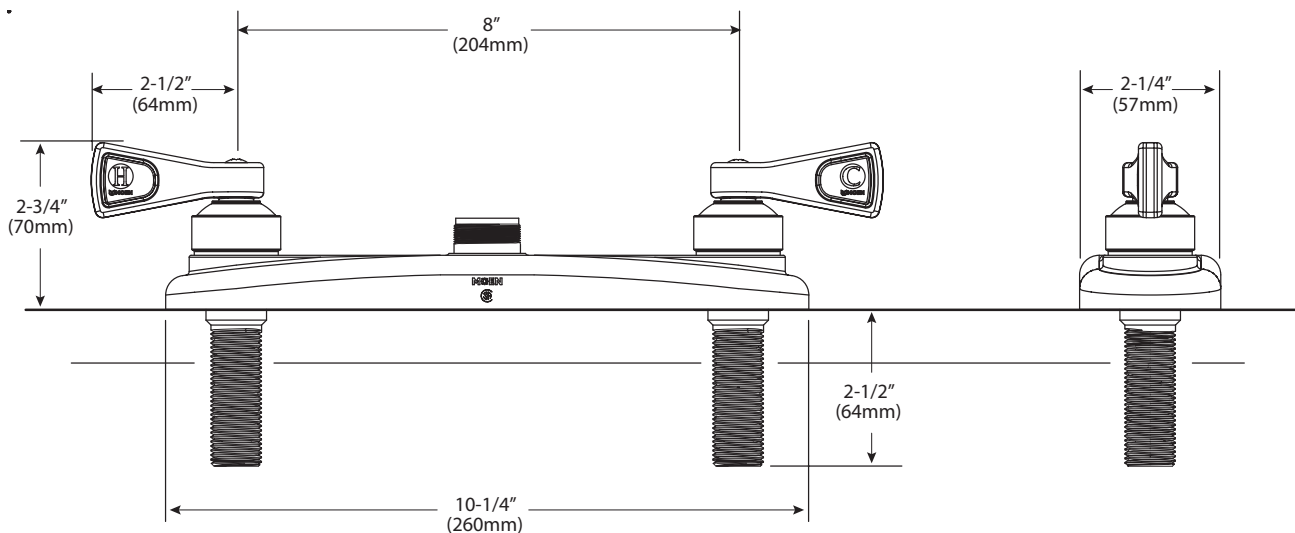

CRITICAL DIMENSIONS DO NOT SCALE