

DESCRIPTION

- Various finishes identified by suffix
- 69" double interlock spiral hose (metal)
- Vacuum breaker
- Adjustable wall bracket

OPERATION

- Three function
- Wall bracket rotates to adjust angle of handshower

FLOW

- Designed to deliver 2.5 gpm max (9.5 L/min) at 80 psi

STANDARDS

- Designed and manufactured to comply with the applicable requirements of CSA B-125.1, ASME A112.18.1 and ASSE 1014 and all applicable specifications referenced therein.

WARRANTY

- Lifetime limited warranty against material or manufacturing defects

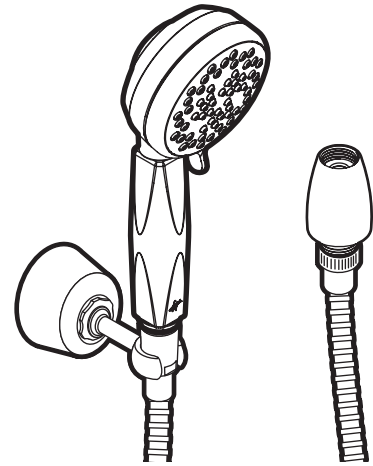

Divine™
Handshower with Bracket & Hose

Models: S155 series

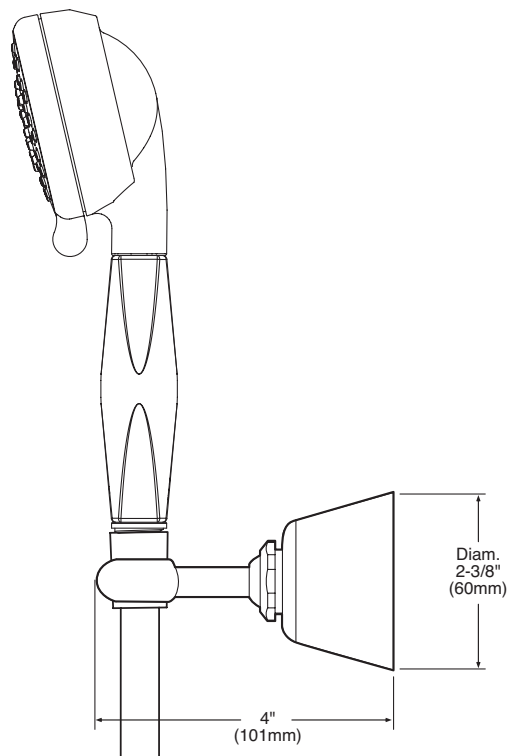

CRITICAL DIMENSIONS

(DO NOT SCALE)