

### Disposal Description

- GTL Series is built for powerful performance and dependable functionality
- Features Motion Activated Lighting
- Fast Track™ enhanced features for faster installation
  - Simple Snap Tool quickly secures mounting assembly
  - Easy Open Dishwasher Inlet: no tools required
- 1 Horsepower VORTEX™ Motor has more grinding power and strength for tougher kitchen tasks
- VORTEX™ Motor features permanent magnet motor technology designed to help reduce jamming
- Universal Xpress Mount™ fits all Moen and most existing 3-bolt mounting assemblies
- Pre-installed power cord - a savings over models where cord must be purchased separately, cord easily removes for optional hardwiring
- SoundSHIELD™ sound deadening insulation
- Compact design frees up valuable space under the sink
- Continuous feed with stainless steel grind components
- Manual Reset Button
- Garbage disposals reduce waste sent to landfills making it an eco-friendly option for your home

### Included Components

- GTL100c Disposal Unit with Universal Xpress Mount™
- Pre-installed Power Cord, Hardwire Capable
- Removable Splash Guard
- Drain Stopper and Stainless Steel Sink Flange
- Drain Elbow and Mounting Assembly
- Simple Snap Tool and Unjamming Wrench

### Warranty & Assurance

- 10 year limited warranty with in-home service
- Safe for use with properly sized septic systems



Model: GTL100c



### Critical Dimensions

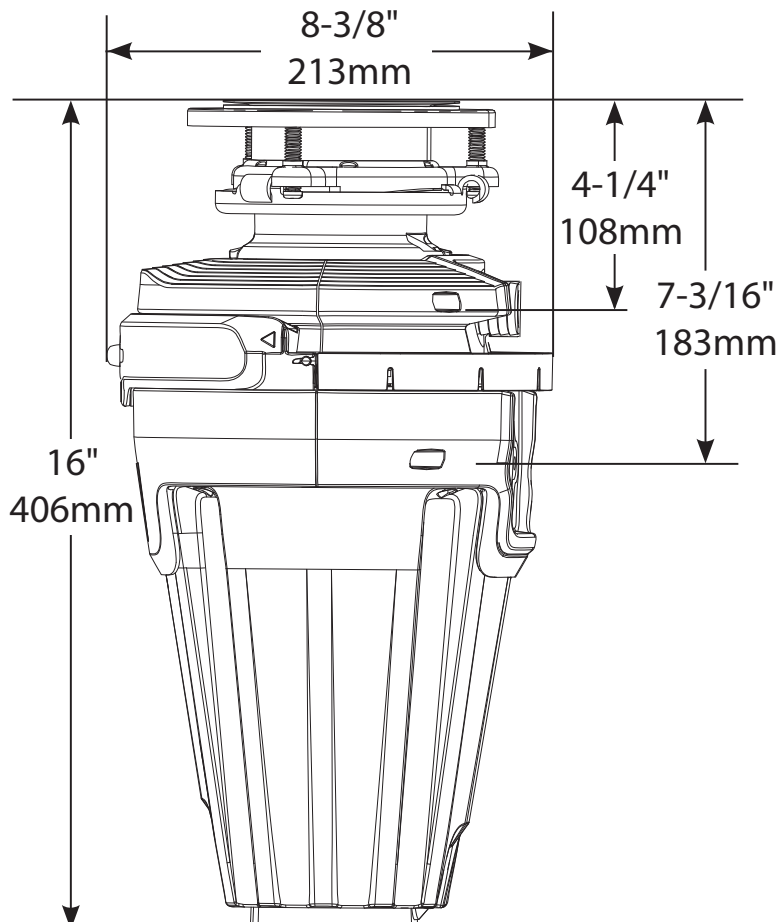

Specification Detail	
Horsepower	1 HP
Feed Type	Continuous
On/Off Controls	Wall Switch
Motor Type	Permanent Magnet Motor
RPM (Revolutions Per Minute)	2800
Weight	13 lbs. / 6 kg
Volts	115
Hz/Amps	60/7.0
Drain Connection Size	1 1/2" / 38mm
Dishwasher Connection Size	7/8" / 22mm
Maximum Sink Thickness	1/2" / 13mm
Sink Drain Flange Finish	Stainless Steel
Grind Component Material	Stainless Steel
Grind Chamber Material	Corrosion Proof Glass Filled Polyester and Nylon