

Whitley™ Technical Specification

Towel Ring

DN1886

Stock Numbers:

- DN1886BRB – Towel Ring
Mediterranean Bronze Finish

Dimensions:

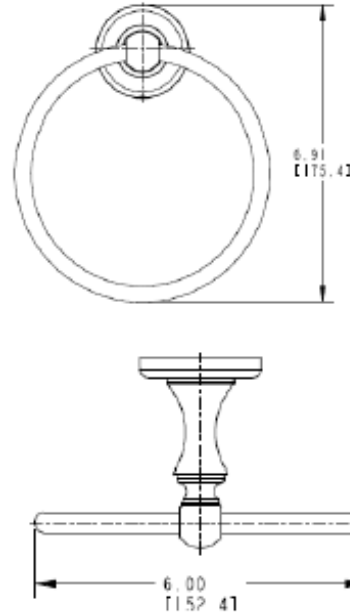

Materials:

Towel Ring post is die cast from highest quality zinc alloy (Zamac). Casting is plated in Mediterranean Bronze. **Towel Ring** is stainless steel.

Installation Instructions:

1. Remove mounting posts from the product assemblies by loosening each setscrew.
2. Position the mounting plate on the wall at desired location with "UP" facing you. Mark hole locations.
3. Drill 2 holes marked using 5/16" drill bit.
4. Fold ends of the plastic toggle anchor together and insert into each hole in the wall.
5. Lightly tap anchors until flush with the wall.
6. One at a time, insert plastic pin into each anchor and lightly tap to activate anchor. Remove pin and repeat on other anchor.
7. Place the mounting plate on the wall over the installed wall anchors with "UP" facing you.
8. Tighten screws.
9. Place decorative product over the mounting plate with the setscrew facing down. Tighten setscrew.

Cleaning Instructions:

To preserve the fine finish of this product, clean only with a soft damp cloth. Dry well. Do not use commercial or abrasive cleaners.

Stock Number: _____ **Towel Ring**
By Creative Specialties



25300 AL MOEN DRIVE • NORTH OLMSTED, OH 44070
CORPORATE HEADQUARTERS: (800) 321-8809 • FAX: (800) 848-6636
INTERNATIONAL: (440) 962-2000 • FAX: (440) 962-2726
CUSTOMER SERVICE (USA): 800-882-0116 • FAX: (888) 379-2720
WWW.MOEN.COM

©Copyright Creative Specialties International

Literature #BA1605