



Buy it for looks. Buy it for life.®

Specifications

DESCRIPTION

- Metal construction with a chrome plated finish
- Pressure balancing valve design with integral check stops, 1/2" CC connections
- Supplied with adjustable temperature limit stop

OPERATION

- Knob style handle, Pull-on push-off design
- Temperature operates through an 180° arc of handle travel (full cold to full hot)
- Adjustable temperature limit stop to control maximum hot water temperature
- Pressure balancing mechanism maintains selected discharge temperature to $\pm 3^\circ$.

CARTRIDGE

- 1225 cartridge design
- Nonmetallic/nonferrous and stainless steel materials
- Accommodates back to back installations

STANDARDS

- Third party certified to meet ASME A112.18.1/CSA B125.1 and all applicable specifications referenced therein

WARRANTY

- Lifetime limited warranty against leaks, drips and finish defects to the original consumer purchaser
- 5 year warranty if used in commercial installations

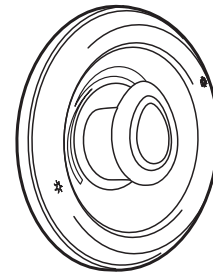

LEGEND® MOENTROL® Single-Handle Tub/Shower Valve

Models: 3170

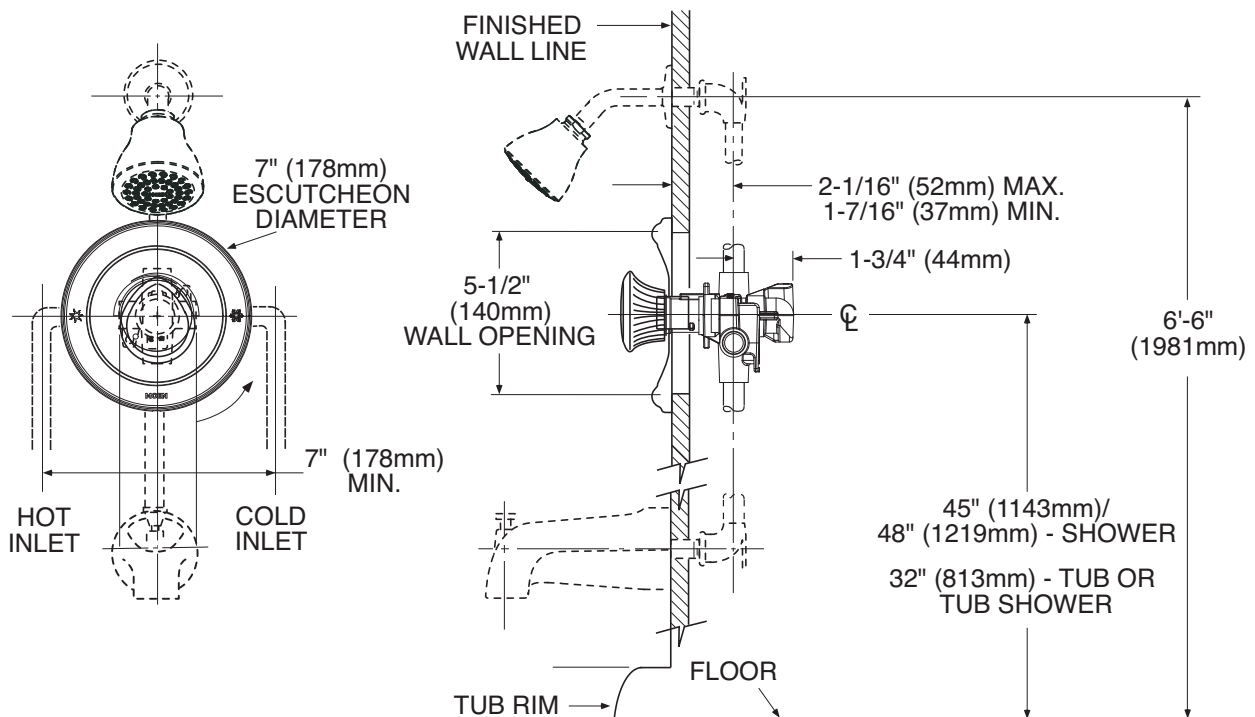

CRITICAL DIMENSIONS

(DO NOT SCALE)

FOR MORE INFORMATION CALL: 1-800-BUY-MOEN

www.moen.com