

# Specifications

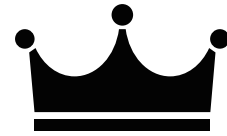

## WASTE KING Model L-1001



### Disposal Description

- EZ Mount twist-and-lock sink flange for fast and easy installation
- 1/2 horsepower disposal provides fast, powerful grinding of everyday food scraps.
- Permanent magnet motor provides fast, powerful grinding which helps reduce jamming.
- Pre-installed power cord for easy plug-in install, no hardwiring or separate purchase required
- Galvanized steel grinding components
- Reinforced polymer grind chamber resists corrosion and extends disposal life
- Continuous feed disposal activates via a wall switch or sink-mounted air switch
- Compact, lightweight design saves space
- Removable, replaceable splash guard
- Safe to use with properly sized septic tanks
- Front-mounted reset button

### Included Components

- Waste King L-1001 EZ Mount Disposal Unit
- Pre-installed power cord
- Removable splash guard
- Reinforced polymer sink flange and drain stopper
- Drain elbow and EZ-Mount mounting assembly

### Critical Dimensions

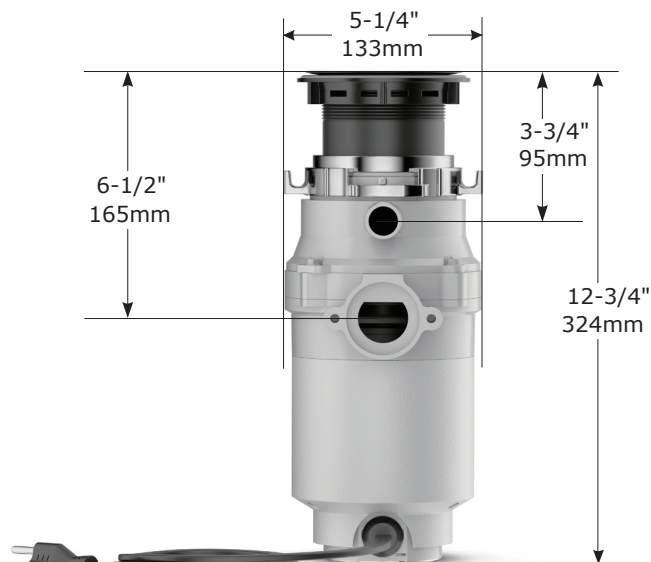

Weight 7.5 lbs.

### Specification Detail

Specification Detail	
Horsepower	1/2
R.P.M.	2600
Mount	EZ Mount
Sound Insulation	No
Warranty	Two Year Limited
Voltage,HZ	115, 60
Current-Amps	4.5
Power Cord	Pre-Installed
Motor Type	Permanent Magnet
On/Off Control	Wall Switch
Drain Connection Size	1-1/2 inch drainpipe
Dishwasher Compatibility	7/8 inch rubber dishwasher drain hose
Maximum Sink Thickness	1/2 inch
Sink Flange Material	Reinforced Polymer
Sink Flange Finish	Stainless Steel
Splash Guard	Removable
Feed	Continuous
Internal Grind Component Material	Galvanized Steel
Grind Chamber Material	Reinforced Polymer
Overload Protector	Manual Reset Type

### Two Year Limited Warranty

If the disposal develops a material or mechanical defect during the warranty period, Waste King will replace it free of charge.

FOR MORE INFORMATION CALL: **1-800-854-3229**  
**WasteKing.com**